

**TANCO BALE HANDLER  
OPERATORS MANUAL  
AND  
PARTS LIST  
WD69-M0420**

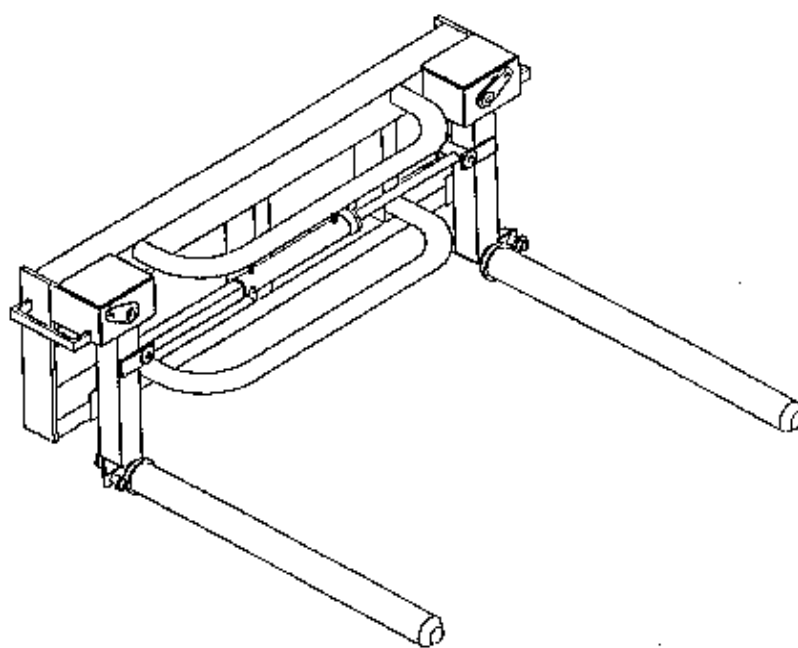

# TANCO BIG BALE HANDLER PARTS LIST

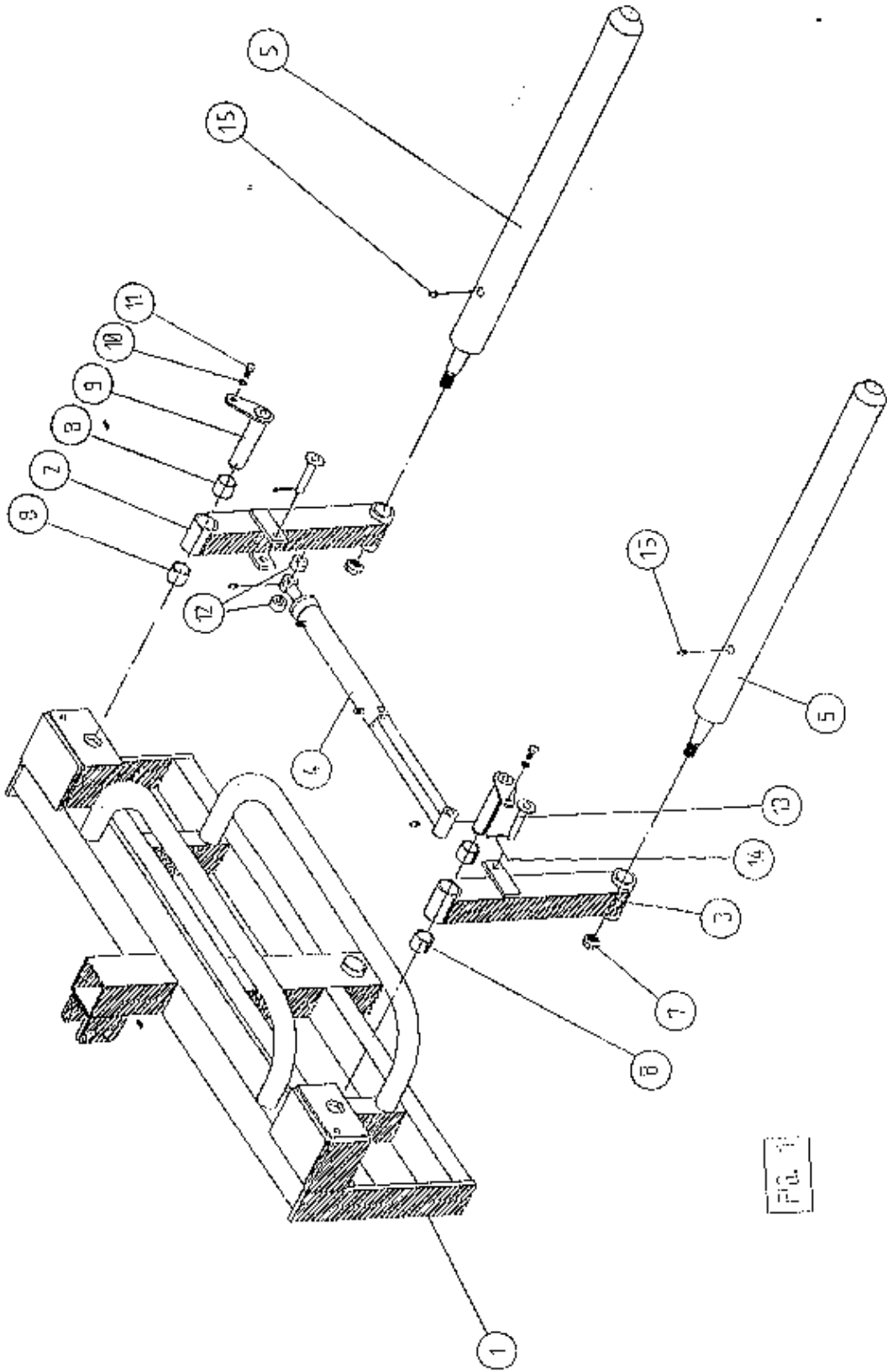

FIG. 1

TANCO BIG BALE HANDLER

WD69-PL2

PARTS LIST

Serial list

ITEM	DESCRIPTION	QTY	PART NO
1	MAIN FRAME ASSEMBLY	1	WD69-MF
2	ARM ASSEMBLY L.H.S	1	WD69-LARM
3	ARM ASSEMBLY R.H.S	1	WD69-RARM
4	HYDRAULIC RAM ASSEMBLY	1	WD69-RAM
5	ROLLER ASSEMBLY	2	WD69-ROL
6	GUARD ASSEMBLY	1	WD69-MG
7	NUT	2	Z001-243
8	TENSION BUSH	4	Z03-20-12
9	ARM PIVOT PIN C/W GR. NIPPLE	2	Z03-12-159
10	12mm DIA. SPRING WASHER	2	Z12-02-12
11	M12 HEX HD SET X 25 LONG	2	Z26-081S
12	SPACER	2	WD69-23
13	RAM PIVOT PIN	2	Z03-08-418
14	2" X 1/4" SPILT PIN	2	Z03-21-29
15			Z39-60

Z01 - Not

Handwritten mark

Handwritten mark

TANCO ROUND BALE HANDLER  
PARTS LIST

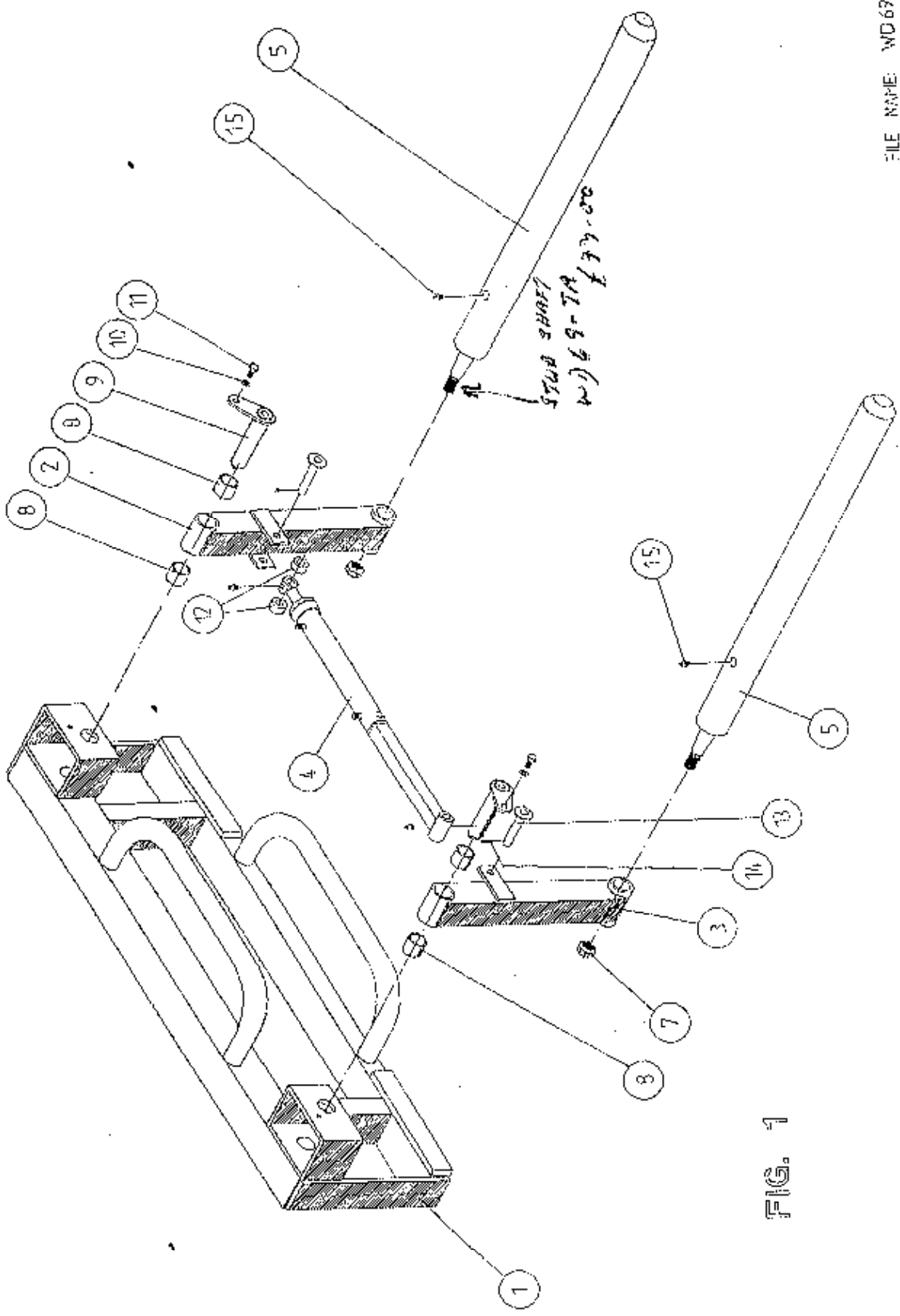

FIG. 1

# TANCO BIG BALE HANDLER (D692)

## PARTS LIST

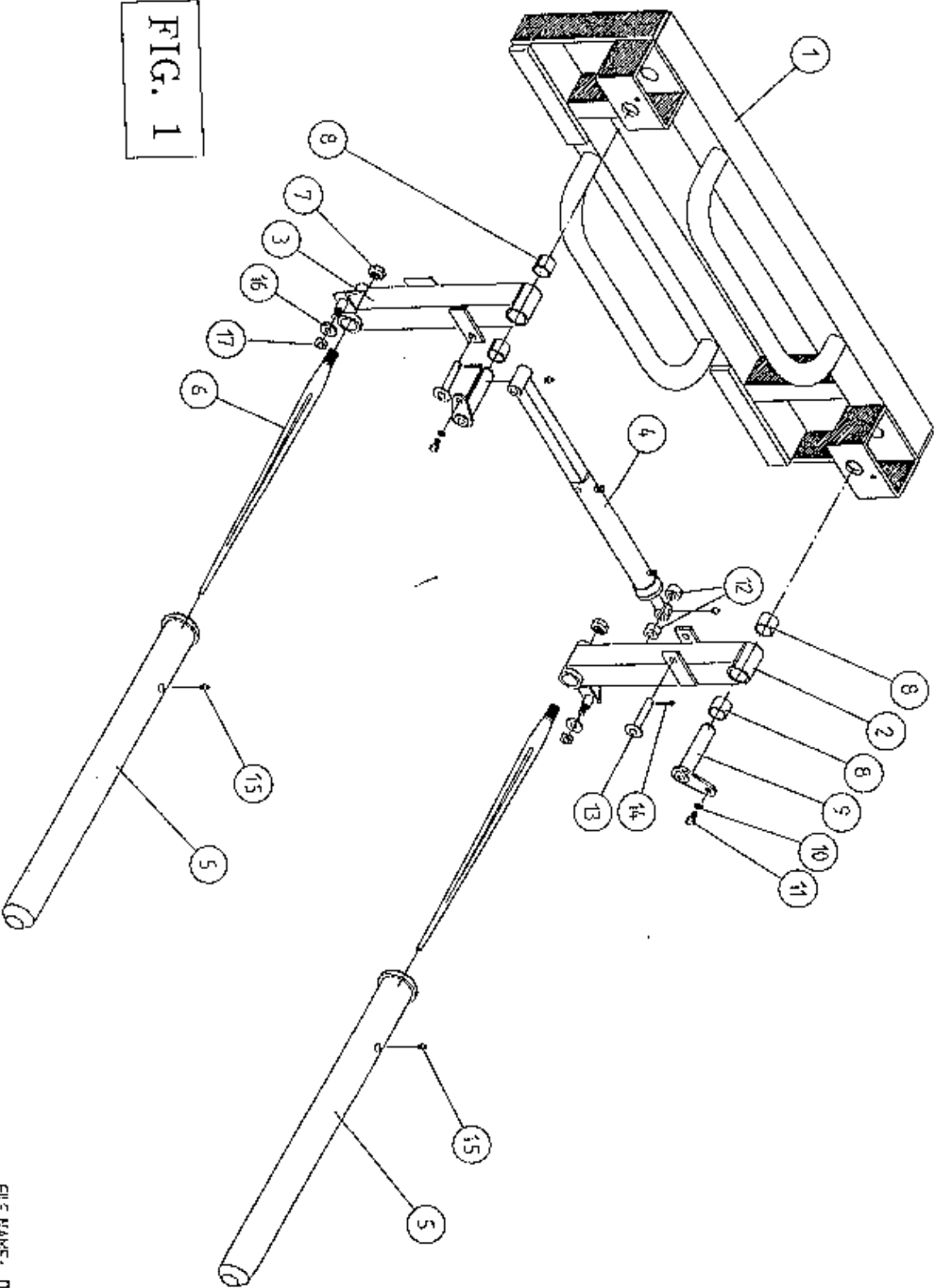

FIG. 1

# TANCO BIG BALE HANDLER

D692-PL

## PARTS LIST

ITEM NO.	DESCRIPTION	QTY	PART NO.
1	MAIN FRAME ASSEMBLY	1	WD691-MF
2	ARM ASSEMBLY L.H.S.	1	WD692-LARM
3	ARM ASSEMBLY R.H.S.	1	WD692-RARM
4	HYDRAULIC RAM ASSEMBLY	1	WD69-RAM <i>201-201</i>
5	ROLLER ASSEMBLY	2	WD692-ROL <i>201-201</i>
6	39" TINE	2	Z001-07
7	NUT	2	Z001-234
8	TENSION BUSH	4	Z03-20-12
9	ARM PIVOT PIN C/W GREASE NIPPLE	2	Z03-12-159
10	10mm DIA SPRING WASHER	2	Z12-02-10
11	M10 HEX HD. SET x 20mm LONG	2	Z26-060S
12	SPACER	2	WD69-23
13	RAM PIVOT PIN	2	Z03-08-418
14	2" x 1/4" SPLIT PIN	2	Z03-21-29
15	1/8" BSP ST. GREASE NIPPLE	2	Z39-60
16	RETAINING COLLAR	2	WD69-57
17	M16 LOCKNUT	2	Z23-16

*201-201 3/Kit*

TANCO ROUND BALE HANDLER  
PARTS LIST

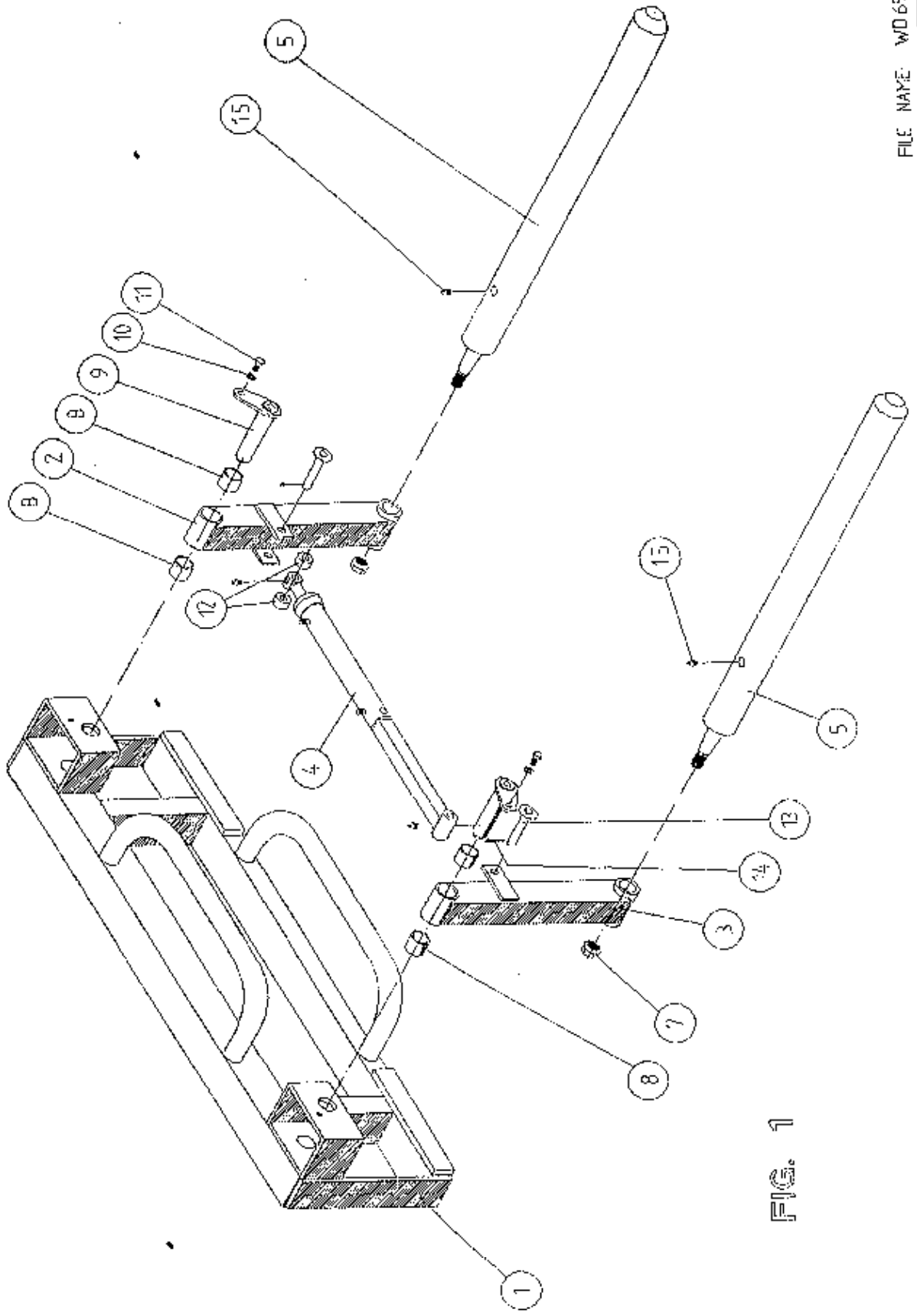

FIG. 1